

HOME GYM HG2011

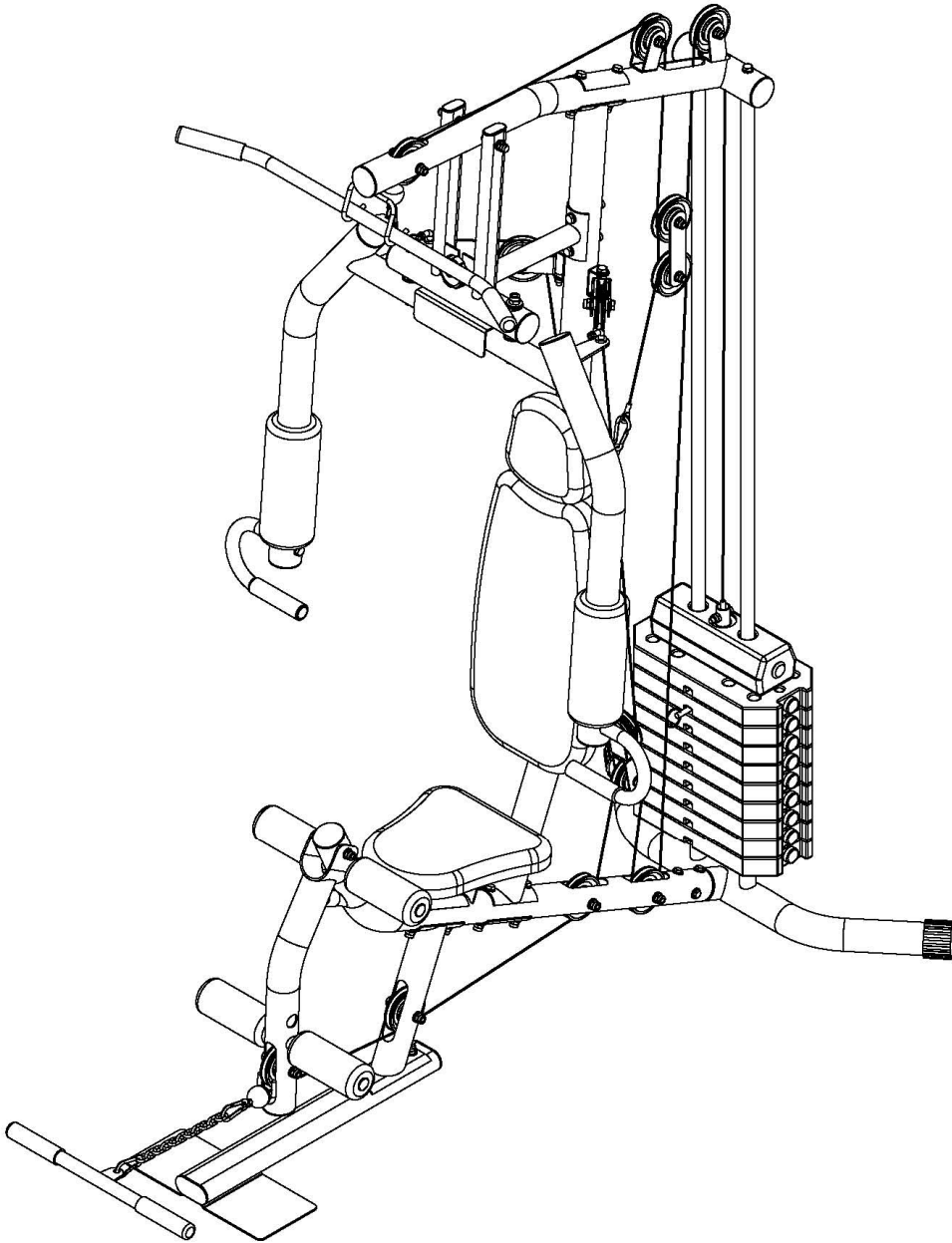

ASSEMBLY INSTRUCTIONS

1) SAFETY INSTRUCTIONS

IMPORTANT!

- This machine is made for home use only and tested up to a maximum body weight of 100 kg.
- This training device should be used only for its intended purpose. Any other use is prohibited and dangerous. The manufacturer cannot be held liable for damage or injury caused by improper use of the equipment.

CAUTION!

1. You are using a machine that has been designed and built to the latest safety standards. Any possible sources of danger that could lead to injury have been extensively eliminated. The machine is intended for use by adults only.
2. Wrong or excessive training can damage your health. Before commencing a course of fitness training, arrange for a medical check-up to see if you are in a state of health suited to training on the machine. The result of the check-up should be used as a basis for your training program.
3. The machine is never to be looked upon as a toy. Please remember that the nature of children who are using the machine can lead to unforeseen situations and hazards for which the manufacturer cannot be held liable.
4. If children are allowed to use the machine, they should be instructed on its correct use and dangerous situations explained to them.
5. The machine must be carefully assembled by an adult. Place it on a flat and strong ground. It must be ensured that the machine is not used until it has been fully assembled.
6. When used for regular training/exercising, we recommend checking all parts of the machine (especially screws, nuts, bolts and ropes) every 1 to 2 months.
7. To maintain the intended level of safety the machine is to be taken out of use if any parts are worn. The worn parts are to be exchanged immediately.
8. Make sure that no adjustment device is left projecting.
9. Please always wear proper training clothes and shoes.

2) PACKAGING

Environment-friendly and recyclable materials:

Outer packing cardboard

Formparts are made of Polystyrol (PS) No FCKW







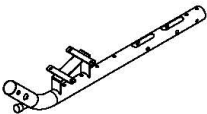
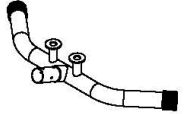
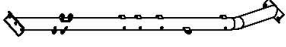
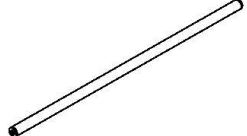
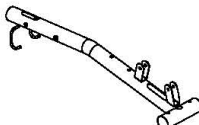
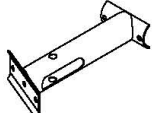
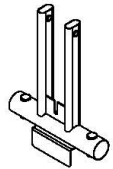
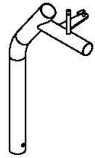
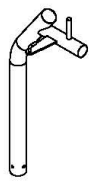
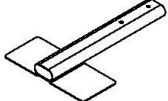
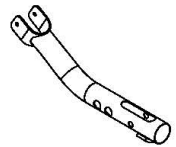
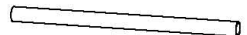

Foils and bags are made of PE

Girths are made of PP

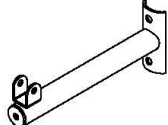
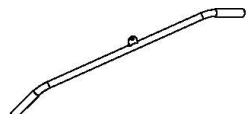
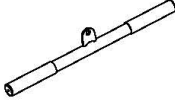
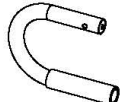
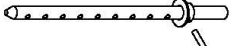
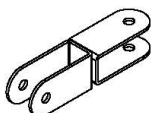
3) DISPOSAL

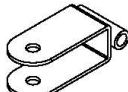
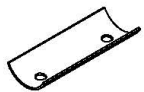

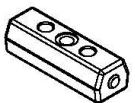
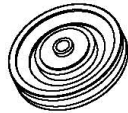
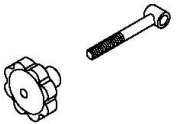





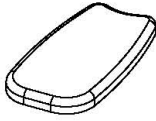
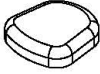

Please dispose packaging properly. Don't put it in the garbage.

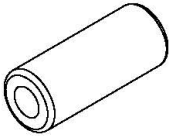
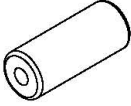
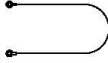
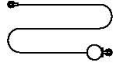
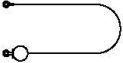
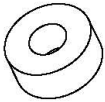
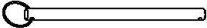
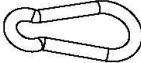
4) PARTS LIST

<p>A</p> 	<p>B</p> 	<p>C</p> 	<p>D</p> 
<p>E</p> 	<p>F</p> 	<p>G</p> 	<p>H</p> 
<p>I</p> 	<p>J</p> 	<p>K</p> 	<p>L</p> 
<p>M</p> 	<p>N</p> 	<p>O</p> 	<p>P</p> 
<p>Q</p> 	<p>R</p> 	<p>S</p> 	<p>T</p> 
<p>U</p> 	<p>V</p> 	<p>W</p> 	<p>X</p> 
<p>Y</p> 	<p>Z</p> 	<p>AA</p> 	<p>AB</p>
<p>AC</p>	<p>AD</p>	<p>AE</p>	<p>AF</p>

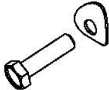
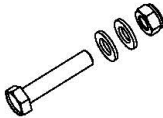
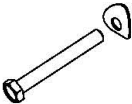
PART LIST

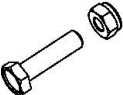
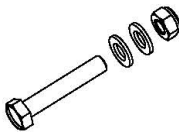
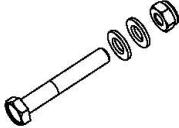
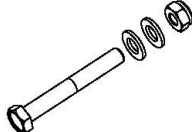
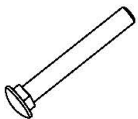
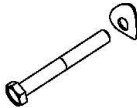
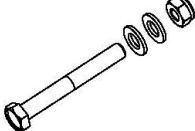
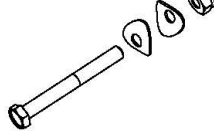
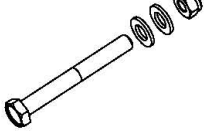
NUMBER	DESCRIPTION	QUANTITY
A	MAIN FRAME	1
B	REAR BASE	1
C	MAIN VERTICAL FRAME	1
D	GUIDE ROD	2
E	TOP CROSS BEAM	1
F	SEAT SUPPORT	1
G	PRESS BAR	1
H	RIGHT CHEST SUPPORT	1
I	LEFT CHEST SUPPORT	1
J	FRONT BASE	1
K	LEG EXTENSION	1
L	FOAM TUBE	2
M	IRON BUSHING	2
N	RESIST BAR	1
O	LAT BAR	1
P	PULL BAR	1
Q	HANDLE BAR	2
R	SELECTOR SHARFT	1
S	UPRIGHT PULLEY BLOCK	1
T	PARALLEL PULLEY BLOCK	2
U	ROTATIONAL PULLEY BLOCK	2
V	REINFORCEMENT PLATE	3
W	WEIGHT PLATE	9
X	TOP PLATE	1
Y	PULLEY	13
Z	LOCK LEVER TUS	1
AA	BUSHING	10

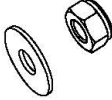
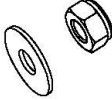
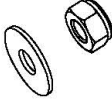
1 	2 	3 	4 
5 	6 	7 	8 
9 	10 	11 	12 
13 	14 	15 	16 
17 	18 	19 	20 
21 	22 	23 	24 
25 	26 	27 	28 
29 	30 	31 	32 

PART LIST

NUMBER	DESCRIPTION	QUANTITY
1	BACKREST CUSHION	1
2	HEADREST CUSHION	1
3	SEAT CUSHION	1
4	BIG FOAM ROLLER	2
5	FOAM ROLLER	4
6	CABLE WITH NO BALL	1
7	LONG CABLE WITH ONE BALL	1
8	SHORT CABLE WITH ONE BALL	1
9	RUBBER DONUT	2
10	PIN	1
11	HOOK	5
12	CHAIN	2
13	BOLT M12×165 + WASHERS + LOCK NUTS	1
14	BOLT M6*16 + WASHER	4
15	BOLT M8*16 + BEND WASHER	4
16	BOLT M8*35 + BEND WASHER	2
17	BOLT M8×40 + TWO WASHERS + LOCK NUT	1
18	BOLT M8*80 + BEND WASHER	4
19	BOLT M12×20 + BEND WASHER	2
20	BOLT M10×35 + LOCK NUT	1
21	BOLT M10×50 + TWO WASHERS + LOCK NUT	8
22	BOLT M10×60 + TWO WASHERS + LOCK NUT	2
23	BOLT M10×70 + TWO WASHERS + LOCK NUT	2
24	SQUARE NECK BOLT M10×75	2
25	BOLT M10×75 + BEND WASHER	2
26	BOLT M10×80 + TWO WASHERS + LOCK NUT	5
27	BOLT M10×80 + BEND WASHERS + LOCK NUT	8
28	BOLT M10×85 + TWO WASHERS + LOCK NUT	1
29	M8 LOCK NUT	2
30	M12 LOCK NUT + BIG WASHER	2

5) ASSEMBLY INSTRUCTION

STEP 01

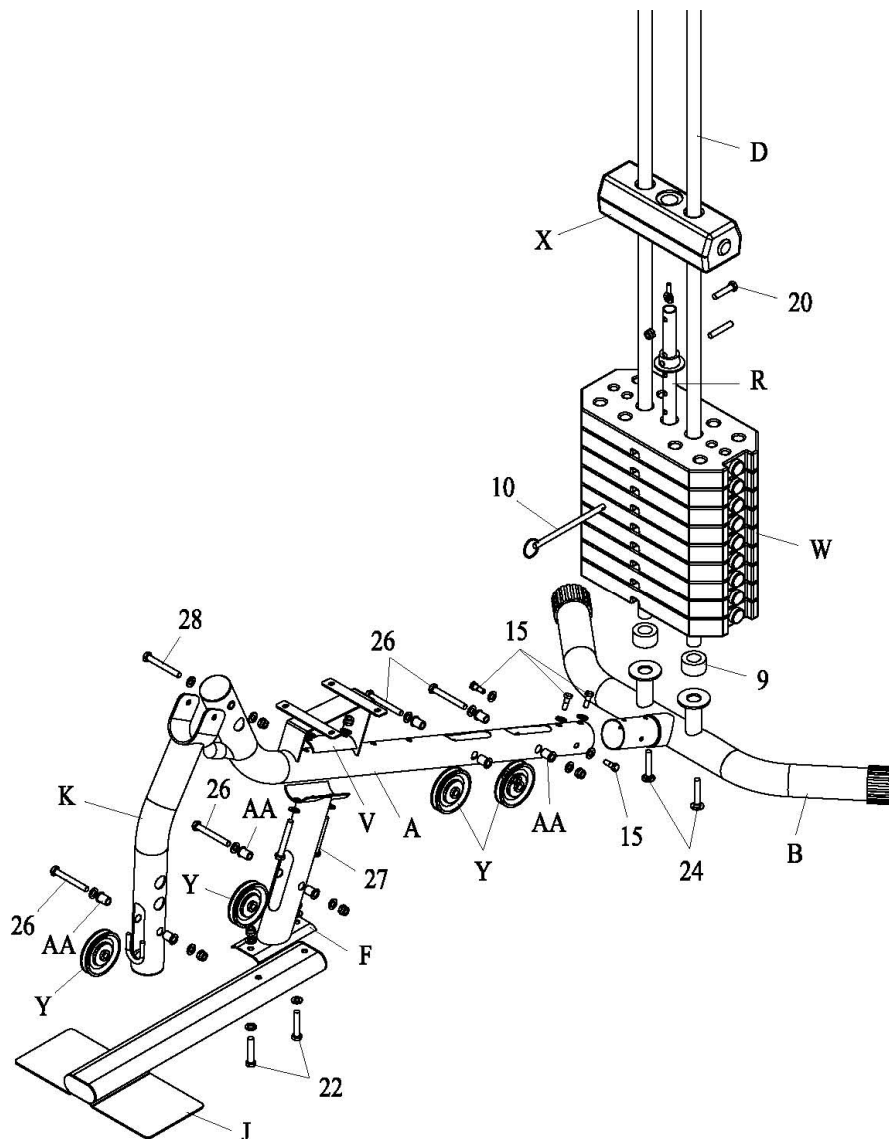

1. Attach rear base (B) to main frame (A) with four bolts M8*16 + bend washers (15).
2. Attach seat support (F) to front base (J) with two bolts M10*60 + washers + lock nuts (22).
3. Attach seat support (F) and reinforcement plate (V) to main frame (A) with two bolts M10*80 + bend washers + lock nuts (27).
4. Insert guide rod (D) into rear base (B) and secure with square neck bolt M10*75 (24).
5. Slide rubber donut (9) and weight plates (W) onto guide rod (D), insert selector shaft (R) into mid hole of weight plate (W). Then slide top plate (X) onto guide rod (D).
6. Attach leg extension (K) to main frame (A) with bolt M10*85 + washers + lock nut (28).
7. Attach pulleys (Y) to main frame (A), seat support (F) and leg extension (K) with bolt M10*80 + washers + lock nut (26) and bushing (AA).

STEP 02

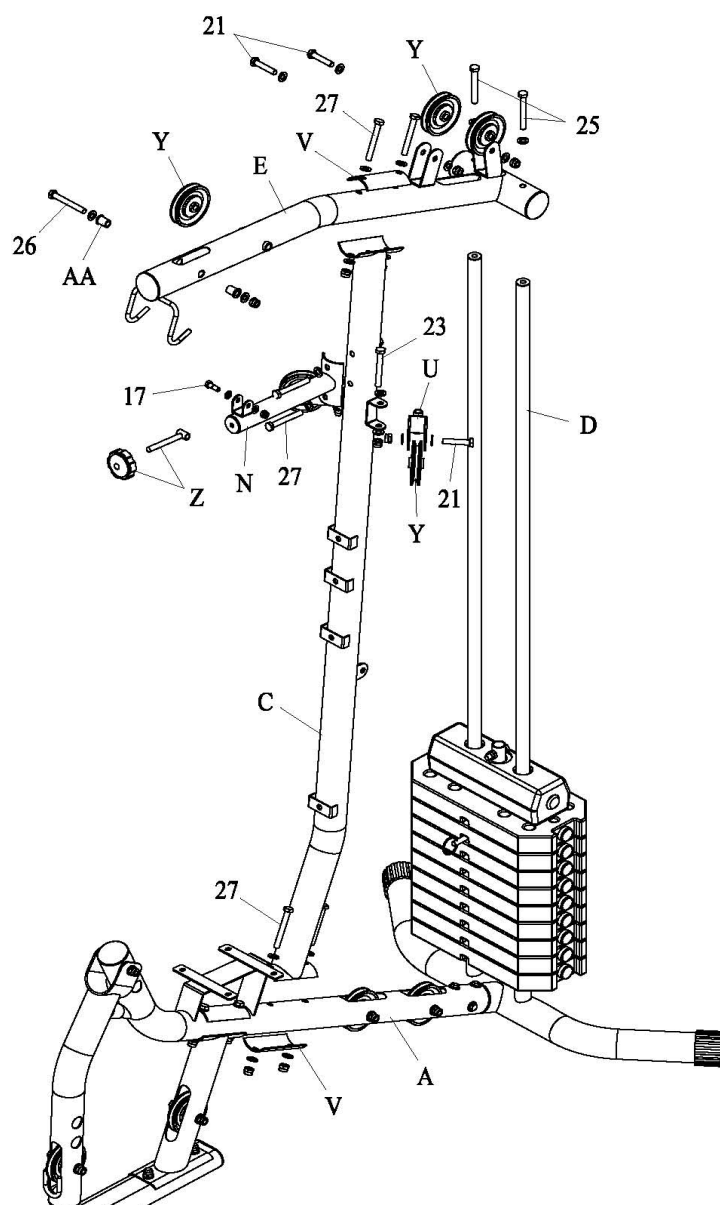

1. Attach main vertical frame (C) and reinforcement plate (V) to main frame (A) with two bolts M10*80 + bend washers + lock nut (27).
2. Attach top cross beam (E) and reinforcement plate (V) to main frame (C) with two bolts M10*80 + bend washers + lock nuts (27).
3. Attach guide rod (D) to top cross beam (E) with two bolts M10*75 + bend washers (25).
4. Attach rotational pulley block (U) to main vertical frame (C) with two bolts M10*70 + washers + lock nuts (23).
5. Attach resist bar (N) to main vertical frame (C) with two bolts M10*80 + bend washers + lock nuts (27).
6. Attach lock lever tus (Z) to resist bar (N) with bolt M8*40 + washers + lock nut (17).
7. Attach one pulley (Y) to front of top cross beam (E) with bolt M10*80 + washers + lock nut (26) and bushing (AA).
8. Attach pulleys (Y) to top cross beam (E) and rotational pulley block (U) with bolt M10*50 + washers + lock nut (21).

STEP 03

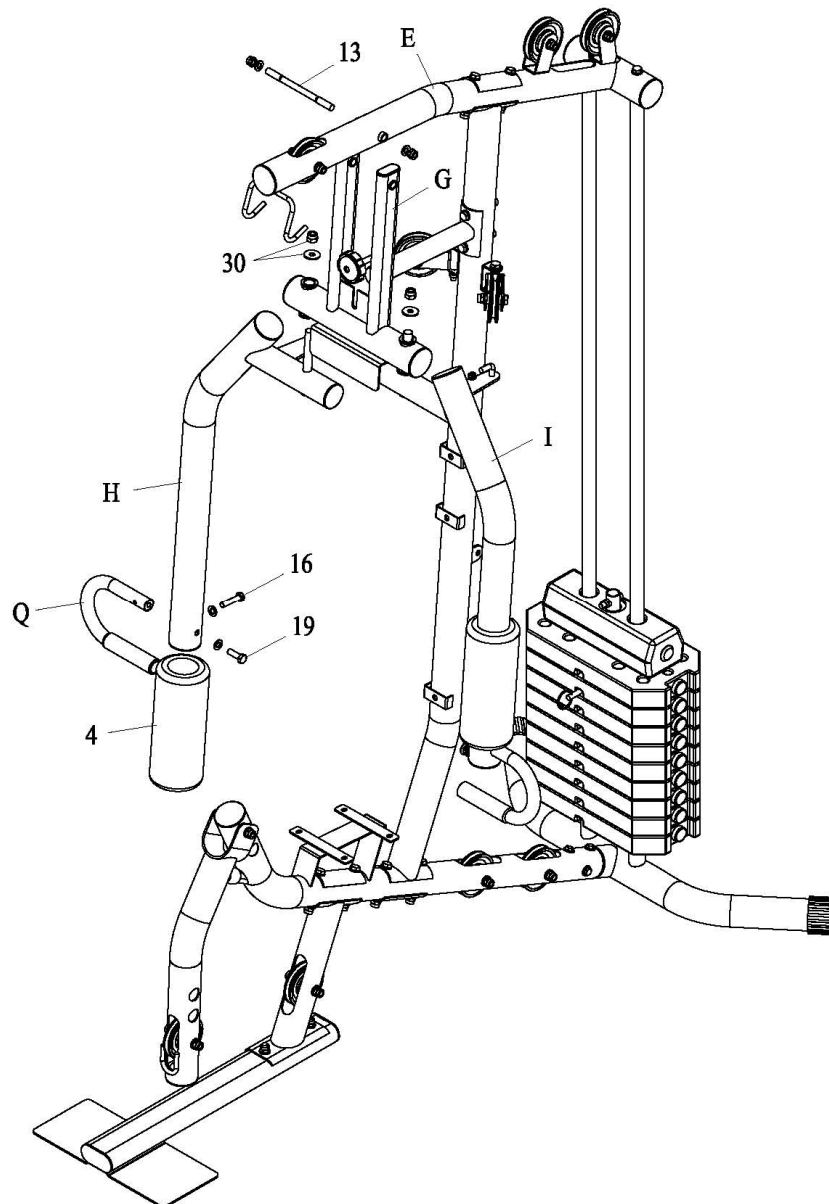

1. Attach press bar (G) to top cross beam (E) with bolt M12*165 + washers + lock nuts (13).
2. Attach right and left chest support (H&I) to press bar (G) with M12 lock nut + big washer (30).
3. Push big foam roller (4) onto right and left chest support (H&I).
4. Secure handle bar (Q) to right and left chest support (H&I) with two bolts M12*20 + bend washers (19) and two bolts M8*35 + bend washers (16).

STEP 04

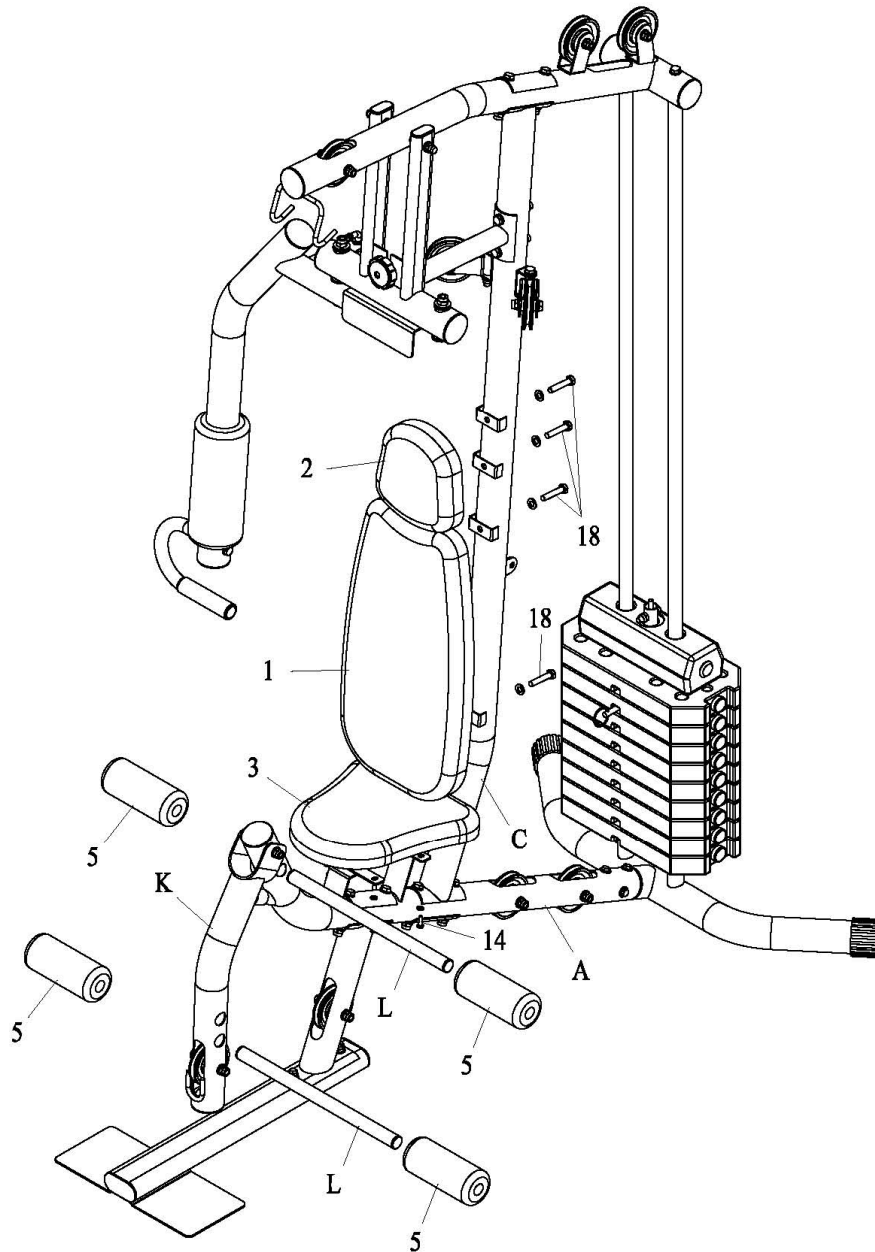

1. Attach seat cushion (3) to main frame (A) with four bolts M6*16 + washers (14).
2. Attach backrest cushion (1) and headrest cushion (2) to main vertical frame (C) with four bolts M8*80 + bend washers (18).
3. Insert foam tube (L) into hole of main frame (A) and leg extension (K).
4. Push foam roller (5) onto each side of foam tube (L).

STEP 05

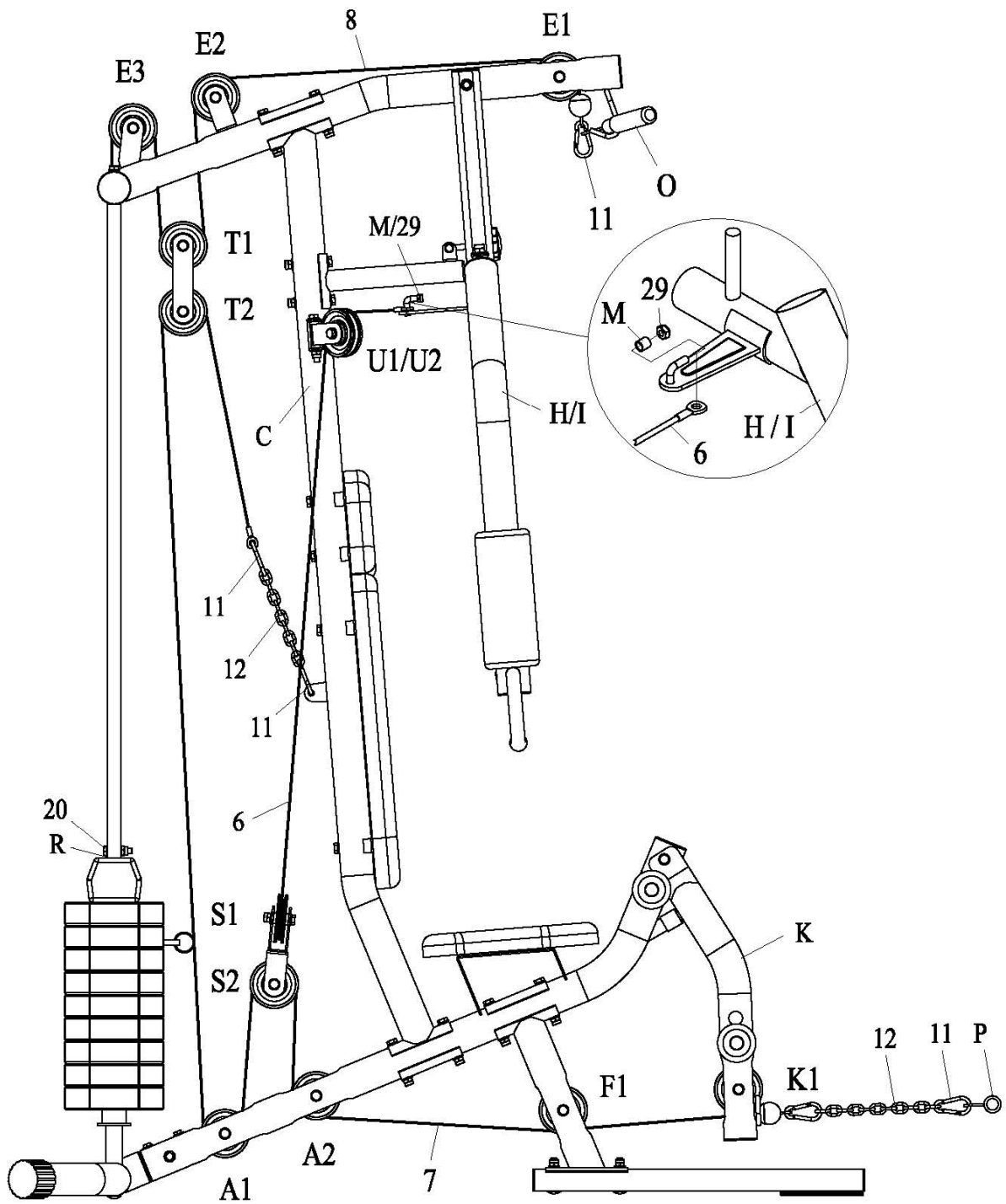

CABLE ASSEMBLY

1. Assembly the cable with no ball (6)

Connect one end of the cable to one of chest support with iron bushing (M) and M8 lock nut (29). Then thread the other end of the cable over pulley U1, down and round pulley S1 on upright pulley block (S), up and over pulley U2, secure cable to chest support with iron bushing (M) and M8 lock nut (29).

2. Assembly the short cable with one ball (8)

Run the end with no ball of the cable (8) through the pulley E1 on top cross beam (E), round the pulley E2 on top cross beam (E), down and under pulley T1 on parallel pulley block (T), up and round pulley E3 on cross beam (E). Attach the end of the cable to the selector shaft (R) with bolt M10*35 + lock nut (20).

3. Assembly the long cable with one ball (7)

Run the end with no ball of the cable (7) through the pulley K1 on leg extension (K), under the pulley F1 on seat support (F), round pulley A2 on main frame (A), up and round pulley S2 on upright pulley block (S), under and round pulley A1 on main frame (A), up and round pulley T2 on parallel pulley block (T), then attach the end to the main vertical frame (C) with hooks (11) and chain (12).

Attach the lat bar (O) to the cable (8) with a hook (11).

Attach the pull bar (P) to the end of the cable (7) on K1 with hooks (11) and chain (12).

6) TRAINING INSTRUCTIONS

IMPORTANT:

Before beginning your training program, consult your doctor to ensure that you are fit enough to use this training device.

Base your program on the result of this medical examination. All following training instructions are suitable for healthy people only.

This training device is a versatile multi-functional home training unit for optimum fitness training with special emphasis on muscle- power. To ensure that your exercising is in keeping with your general health, please read the following instructions and observe them at all times:

1. Newcomers should avoid using excessively heavy weights.
2. During start-up sessions, use weights that can be used for 15 repetitions without gasping for breath.
3. Always breathe regularly: breathe out when pushing against the load (concentric phase) and breathe in when releasing it (eccentric phase). Avoid forced breathing.
4. Carry out all movements evenly and smoothly without jerking.
5. All movements should be carried out to their full extent to prevent contraction of the muscles. However, in the bending and stretching positions ensure that the muscles are tense enough to minimize strain on the joints.
6. Pay particular attention to keeping your back in a stable position. To ensure this, keep the tension of the belly muscles constant during exercising.
7. Always remember that your tendons and joints do not develop as quickly as your strength and muscle power. For this reason increase the amount of exercise in the following order:
 - a. First increase your exercising frequency (number of exercising sessions per week)
 - b. Increase the length of your exercising sessions (number of sets per exercise)
 - c. Then increase the exercising strain (i.e. increase the weights used)

Recommendation for exercising

For general fitness and health the most suitable types of training are strength and endurance training as well as training aimed at building up the muscles (hypertrophy training).

For strength and endurance exercising it is best to use lighter weights (approx. 40-50% of maximum force*) and brisk but controlled speed of movement. The number of repeats should be between 16 and 20.

For exercises designed to build up muscles, it is advisable to use heavier weights (approx. 60-80% of maximum force*) with a moderately slow speed of movement.

After about four weeks of strength and endurance exercising, a moderate program of muscular exercising can be begun. For older people it is especially important to maintain and build up muscle mass in order to relieve unnecessary strain on the joints.

Always start your session with a set of exercises to warm up. Make use of intervals to do loosening-up exercises. Exercise 2-3 times per week and take every opportunity to exercise in different ways e.g. by walking, jogging, cycling and swimming.

You will soon notice that regular exercise increases your general fitness and sense of wellbeing.

WARMING UP

Start with 5 to 10 minutes of stretching and light exercise. A warm-up increases your body temperature, heart rate, and circulation in preparation for exercise.

COOLING DOWN

Finish with 5 to 10 minutes of stretching. Stretching increases the flexibility of your muscles and helps to prevent post-exercise problems.

7) EXERCISES

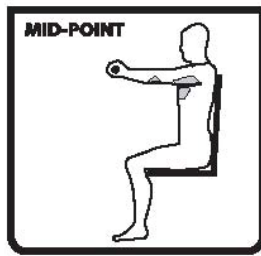
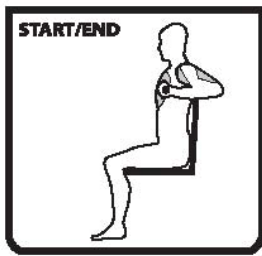

CHEST PRESS

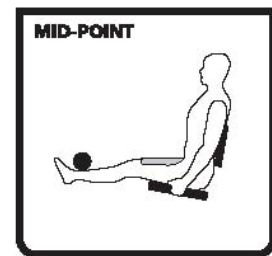
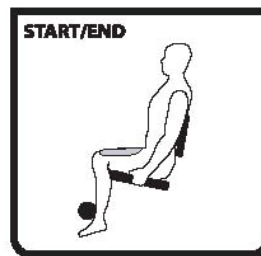

LEG EXTENSION

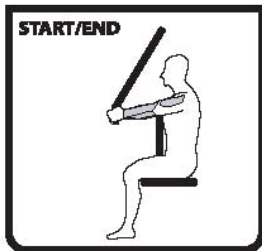

SEATED MID ROW

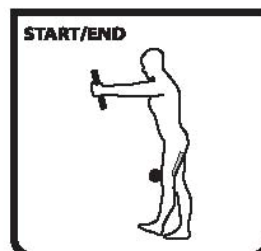

LEG CURL

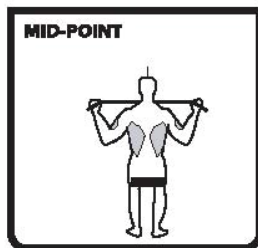
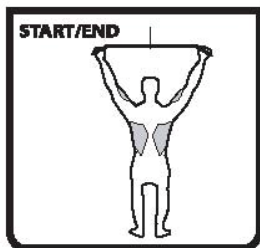

LAT PULL DOWN

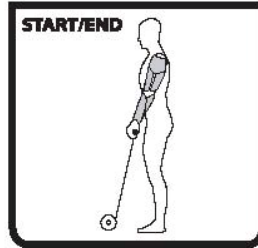

UPRIGHT ROW

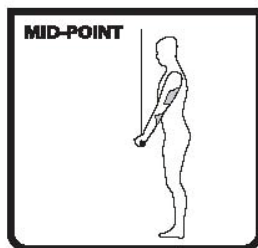
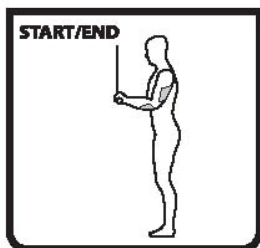

TRICEP PUSH DOWN

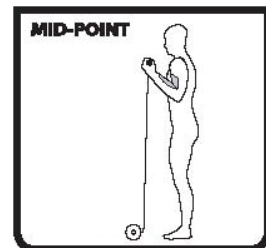
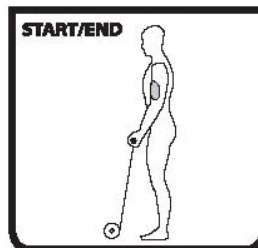

ARM CURL

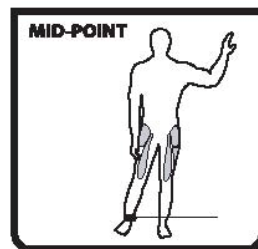

OUTER THIGH

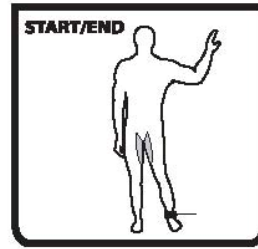

INNER THIGH

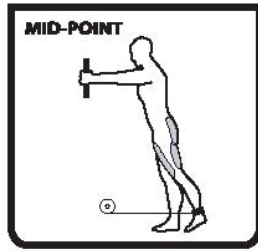
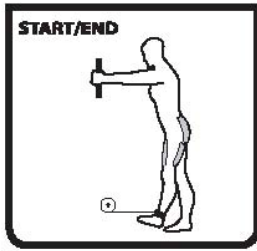

BACK KICK

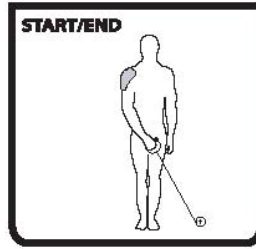

DELTOID RAISE



SIDE BEND