



USER MANUAL – EN

**IN 21966, 21967, 21968, 23319, 23320 Freestyle scooter
inSPORTline Mantis, Osprey, Vulture, Vixen, Baracuda**

CONTENTS

- SAFETY INSTRUCTIONS..... 3
- WARNING 3
- BASIC SAFETY RULES..... 3
- ASSEMBLY 4
- BEFORE AND AFTER USE 5
- RIDING INSTRUCTIONS..... 5
- COMPRESION SYSTEM (if available)..... 6
- MAINTENANCE 6
- ENVIRONMENT PROTECTION 7
- TERMS AND CONDITIONS OF WARRANTY, WARRANTY CLAIMS..... 8

SAFETY INSTRUCTIONS

- Read the manual carefully before assembly.
- Check if all the screws and nuts are tightened before every ride.
- For your safety, always use a helmet, knee, elbow and wrist protectors and solid shoes. Do not ride the scooter without shoes.
- Do not use the scooter on wet surfaces, sand, leaves, etc.
- The basic version of the scooter is not suited for roads with car traffic or for riding in the dark.
- Regularly check the screw connections, tightening mechanisms, brakes and the setting of the steering mechanism to avoid an eventual accident while riding.
- We do not recommend to modify this scooter in any way.
- Do not brake rapidly and suddenly – you could fall down.
- The manufacturer is not responsible for any damage that may occur while using this product.
- This scooter is for one person only.
- Do not try to modify the scooter by yourselves.
- Certification: EN 14619:2019, class A
- **WARNING:** Mechanisms for decreasing speed (brake lining, rims, tires, rear and foot brakes) can become heated during use. Therefore, you should not touch them after braking.
- USE AVAILABLE PROTECTIVE EQUIPMENT WHILE RIDING THIS SCOOTER (HELMET, GLOVES. ETC.)
- Weight limit: 100 kg

WARNING

Device is not suitable for kids 36 months old or younger, has unstable base, there is a risk of falling.

Suitable for kids 7 years and older.

BASIC SAFETY RULES

Riding a scooter can be risky. While driving, dangerous situations can occur, which can lead to a fall or accident and cause serious or fatal injuries. RIDING A SCOOTER IS NOT DIFFERENT FROM RIDING TO ANY OTHER VEHICLE, AND THERE IS A RISK AND THAT MAY RESULT IN SERIOUS INJURIES OR DEATH, EVEN WHEN FOLLOWING ALL SAFETY RULES.

- Only one person can ride the scooter. Maximum load: 100 kg.
- Children can only use the scooter under adult supervision.
- Ride the scooter only in safe places, i.e. on a flat, clean, and dry surface with plenty of free space without any obstacles, stones, or gravel. Do not ride on public roads or roads intended for motor vehicles.
- Before driving, check that the control system is set up correctly, that all bolts and levers are tightened, that the wheels are fastened and working as intended. All parts must be properly secured and must not show signs of mechanical damage.
- Wear protective equipment - helmet and knee, elbow, and wrist protectors.
- Do not ride the scooter in low visibility (at night or dusk) or in humid or freezing weather.
- After riding, check the condition of the parts (especially the connecting material) again and make sure that they did not come loose, break or are dirty from dirt, oil or surface and do not show signs of wear. The scooter must be fully functional before each ride.

- Familiarize yourself with local rules and regulations before driving on public roads.
- Do not overestimate yourself and take extra care while driving.
- Wear sports shoes while riding a scooter. Do not ride barefoot or in open shoes. Be careful not to entangle the laces in the wheels.
- Avoid wet surfaces, sand, gravel, deceleration sills, and other obstacles that could cause the front wheel to lock. It is especially dangerous to cross deceleration thresholds, so avoid riding over them.
- Do not ride on public roads intended for motor vehicles and pay attention to your surroundings, pedestrians, cyclists, skateboarders, and other scooters. Use the scooter only in safe places without any obstacles. Pillars, curbs, hydrants, parked vehicles, and surrounding vehicles can endanger your safety.
- This scooter is not intended for riding on uneven surfaces (paving blocks, field roads, etc.). Defects caused by incorrect use of the product cannot be accepted as a claim. You can see various tricks with a scooter on the TV or internet. However, these tricks were preceded by a very long training. Do not try any tricks unless you are sufficiently prepared for them. The rear wheel cover (fender) is used to stop. When you step on it, the scooter slows down to a stop. When braking, the fender heats up, so do not touch it after braking.

WARNING: FAILURE TO FOLLOW COMMON SENSE AND OBEYING THE SAFETY INSTRUCTIONS WILL INCREASE THE RISK OF SERIOUS INJURY. USE THE SCOOTER AT YOUR OWN RISK AND FOLLOW ALL SAFETY INSTRUCTIONS HOW TO HANDLE THE PRODUCT. BE CAREFUL.

ASSEMBLY

Assembly can be done by adult person.

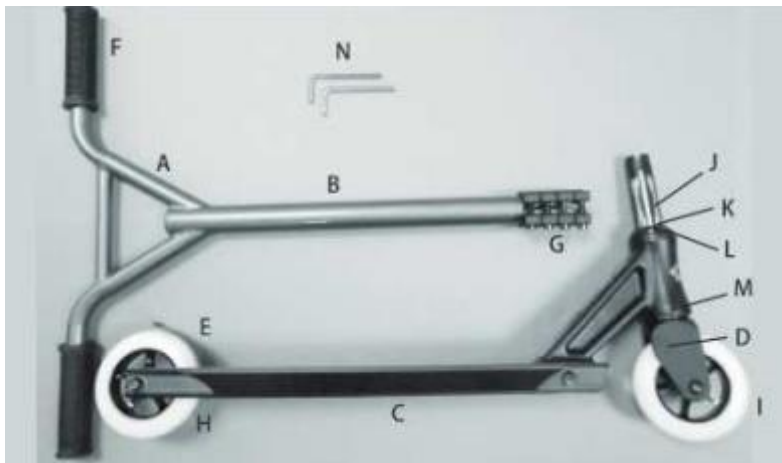

- A – Handles
- B – Handlebars
- C – Deck
- D – Front fork
- E – Rear fender / brake
- F – Grips
- G – Clamp
- H – Rear wheel
- I – Front wheel
- J – Compression pad
- K – Protective sleeve
- L – Sleeve
- M – Washer
- N – Allen keys

Adjust the handlebars so that it is perpendicular to the front wheel in direction of travel, front wheel must be in line with deck (must face forward).

After each use, check that all bolts are tighten.

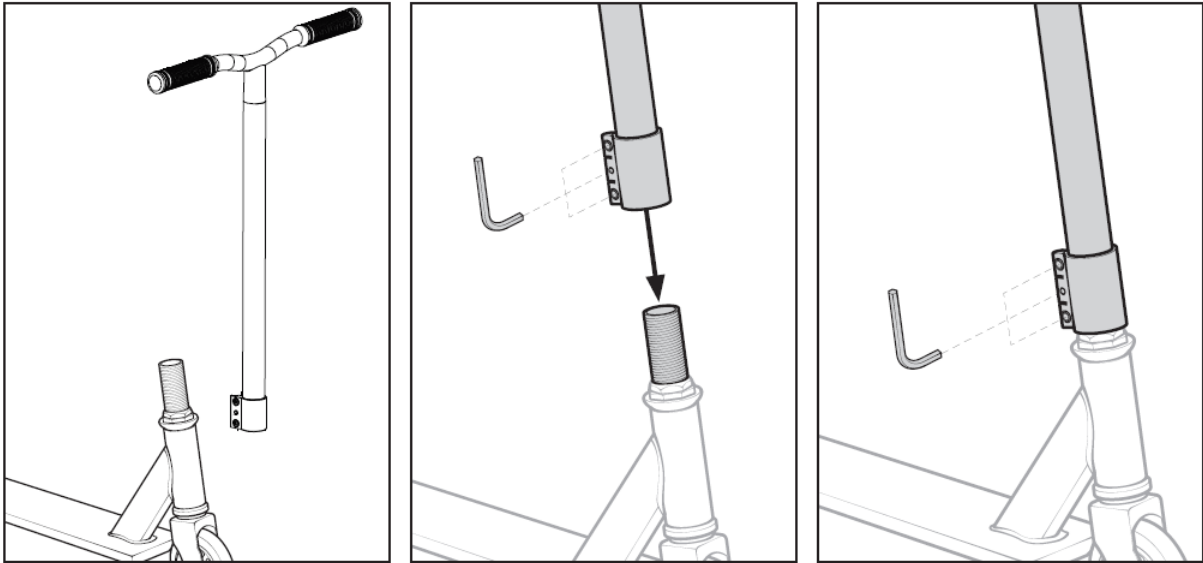

WARNING: Supplied accessories are compatible with the frame, fork, and other parts. Accessories from other manufacturers may not be compatible. Do not make any interventions in the construction of the scooter, it could reduce its safety. Consult your dealer for replacement or repair of any part.

WARNING: BEFORE EACH RIDE, CHECK THE OVERALL CONDITION OF THE SCOOTER, CORRECT ADJUSTMENT OF THE STEERING SYSTEM AND MAKE SURE THAT ALL PARTS ARE PROPERLY LOCKED AND FULLY FUNCTIONAL. PERFORMING PERIODIC SCOOTER INSPECTIONS AND PROPER MAINTENANCE REDUCE THE RISK OF ACCIDENT.

BEFORE AND AFTER USE

- Make sure that the locking mechanisms are properly secured.
- Check the tightening of the nuts, the perpendicularity of the handlebars and the front wheel.
- Check the connection systems: the brakes, wheel axles must be correctly adjusted and must not be damaged.
- At the same time, check the wear of the wheels.

RIDING INSTRUCTIONS

- a) The scooter must be used with caution, as riding it requires great skill. The ability to ride and maintain balance with the body to prevent falls and accidents that cause injuries to the user and others.
- b) The user stands on the deck (step) while riding, bounces off the ground and steers the handlebars. Rotate the bounce leg regularly.
- c) Hold both handles (with both hands) when riding. Reduce speed when turning or not going straight, you may lose your balance.
- d) Before leaving the scooter, the speed must be reduced. After stopping the scooter completely, leave with one leg first and then the other.
- e) To reduce speed, step on the part above the rear wheel of the scooter. Pressing this part (fender) will slow down or even stop the scooter.
- f) Do not jump off the scooter while riding.
- g) The slow down mechanism heats up during continuous use. Therefore, always release it completely after each braking. For the same reasons, it is also not advisable to touch the brake mechanism immediately after stopping.

- h) Beginners should start using the scooter under the supervision of another (adult) person who will help maintain balance, etc.
- i) Before riding the scooter, test the controls to avoid falling or other incidents.
- j) When riding downhill, the braking distance is extended, and the safety is reduced. The rider must always ride at such a speed that he is able to stop in time and safely.

COMPRESION SYSTEM (if available)

The head assembly must be compressed at the same time for it to work properly. The compression system provides the necessary pressure so that the bearings are in the right place. If properly adjusted, it allows the bearings to rotate freely and smoothly. Internal bearings are consumables and must be replaced regularly to achieve the best possible performance over time.

To get the best performance, your product must be properly assembled. It must not move back and forth and must not be too loose or too tight.

Step 1: Release the clamp and remove the control rod by pulling it out of the fork. Loosen the front axle and remove the front wheel.

Step 2: Place the end of the adjusting rod in the fork and insert the Allen key so that the nut cannot turn. Now adjust the head assembly. To anchor it, turn it clockwise, to release it, turn it counterclockwise. It may happen that the wheel will turn easily after adjustment but remember that it is not a "game", and everything must fit firmly. Finally, put the whole scooter together.



MAINTENANCE

We recommend entrusting the maintenance of your scooter to a professional service.

- **Bearings:** Be careful not to drive over water, oil, or sand, as this could damage the bearings. To keep the bearings in good condition, regularly check that the wheels move correctly - turn over the scooter and move the wheels with your fingers. If they do not rotate, they must be removed and checked for condition. First unscrew the wheel axle, remove the axle, remove the wheel, and carefully push out both bearings. If they are torn or compressed, new ones must be purchased. If no damage is visible, they must be oiled. In this case, use a paper towel or cloth to remove any grease, mud, or dust from the bearings, lubricate the bearings with self-lubricating spray or Vaseline. Place back the bearings, axle, and wheel on the scooter. Continue in the same way for the second wheel. If you lack knowledge of the bearings in detail, then the basic precondition for choosing suitable bearings is the manufacturer and the price. In most cases, it is true that a proven manufacturer will offer a quality bearing regardless of the designation and standard, and vice versa, buying bearings from an unknown manufacturer without prior consultation or experience with the bearing type is a risk, regardless of whether the bearing is marked ABEC 5 or ABEC 9. It is also often the case that

bearings for € 20 will be of better quality than bearings for € 10, again regardless of their specific designation.

- **Wheels:** Wheels wear out after a while or may be punctured if used frequently on a rough surface. Especially the rear wheel, which brakes. It is recommended to check them regularly and replace them for safety reasons.
- **Product modifications:** The original product must not be modified in any way, except in the cases mentioned in this maintenance manual.
- **Nuts, axles, and other self-locking clamping systems:** It is recommended to check them regularly. They can either be loose after a certain time, in which case they need to be retightened, or they lose their effectiveness, in which case they need to be replaced with new ones.
- **Frame, fork, and handles:** Check the joints for cracks or fissures. The frame rarely breaks. Nevertheless, it can be damaged, bent or cracked, especially in the event of a sharp impact at high speed. Regularly check the overall condition of the construction. If you find damage on the frame, do not use the scooter.

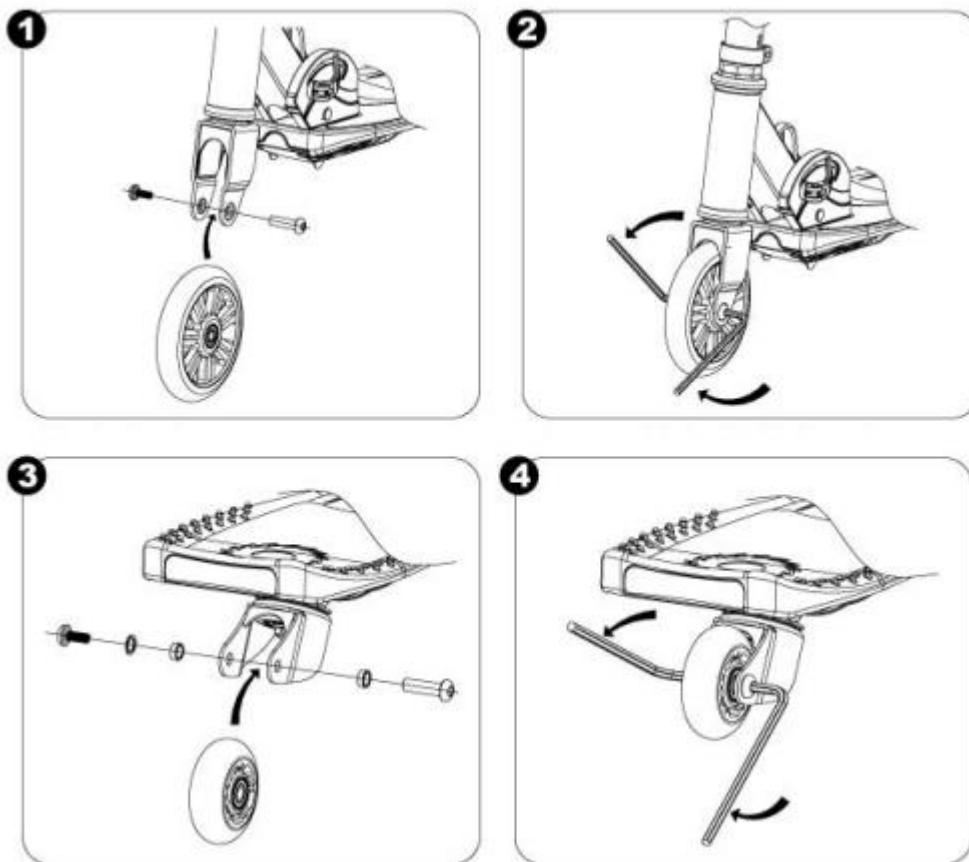

ENVIRONMENT PROTECTION

After the product lifespan expired or if the possible repairing is uneconomic, dispose it according to the local laws and environmentally friendly in the nearest scrapyards.

By proper disposal you will protect the environment and natural sources. Moreover, you can help protect human health. If you are not sure in correct disposing, ask local authorities to avoid law violation or sanctions.

Don't put the batteries among house waste but hand them in to the recycling place.

TERMS AND CONDITIONS OF WARRANTY, WARRANTY CLAIMS

General Conditions of Warranty and Definition of Terms

All Warranty Conditions stated here under determine Warranty Coverage and Warranty Claim Procedure. Conditions of Warranty and Warranty Claims are governed by Act No. 89/2012 Coll. Civil Code, and Act No. 634/1992 Coll., Consumer Protection, as amended, also in cases that are not specified by these Warranty rules.

The seller is SEVEN SPORT s.r.o. with its registered office in Strakonická street 1151/2c, Prague 150 00, Company Registration Number: 26847264, registered in the Trade Register at Regional Court in Prague, Section C, Insert No. 116888.

According to valid legal regulations it depends whether the Buyer is the End Customer or not.

“The Buyer who is the End Customer” or simply the “End Customer” is the legal entity that does not conclude and execute the Contract in order to run or promote his own trade or business activities.

“The Buyer who is not the End Customer” is a Businessman that buys Goods or uses services for the purpose of using the Goods or services for his own business activities. The Buyer conforms to the General Purchase Agreement and business conditions.

These Conditions of Warranty and Warranty Claims are an integral part of every Purchase Agreement made between the Seller and the Buyer. All Warranty Conditions are valid and binding, unless otherwise specified in the Purchase Agreement, in the Amendment to this Contract or in another written agreement.

Warranty Conditions

Warranty Period

The Seller provides the Buyer a 24 months Warranty for Goods Quality, unless otherwise specified in the Certificate of Warranty, Invoice, Bill of Delivery or other documents related to the Goods. The legal warranty period provided to the Consumer is not affected.

By the Warranty for Goods Quality, the Seller guarantees that the delivered Goods shall be, for a certain period of time, suitable for regular or contracted use, and that the Goods shall maintain its regular or contracted features.

The Warranty does not cover defects resulting from (if applicable):

- User's fault, i.e. product damage caused by unqualified repair work, improper assembly, insufficient insertion of seat post into frame, insufficient tightening of pedals and cranks
- Improper maintenance
- Mechanical damages
- Regular use (e.g. wearing out of rubber and plastic parts, moving mechanisms, joints, wear of brake pads/blocks, chain, tires, cassette/multi wheel etc.)
- Unavoidable event, natural disaster
- Adjustments made by unqualified person
- Improper maintenance, improper placement, damages caused by low or high temperature, water, inappropriate pressure, shocks, intentional changes in design or construction etc.

Warranty Claim Procedure

The Buyer is obliged to check the Goods delivered by the Seller immediately after taking the responsibility for the Goods and its damages, i.e. immediately after its delivery. The Buyer must check the Goods so that he discovers all the defects that can be discovered by such check.

When making a Warranty Claim the Buyer is obliged, on request of the Seller, to prove the purchase and validity of the claim by the Invoice or Bill of Delivery that includes the product's serial number, or eventually by the documents without the serial number. If the Buyer does not prove the validity of the Warranty Claim by these documents, the Seller has the right to reject the Warranty Claim.

If the Buyer gives notice of a defect that is not covered by the Warranty (e.g. in the case that the Warranty Conditions were not fulfilled or in the case of reporting the defect by mistake etc.), the Seller is eligible to require a compensation for all the costs arising from the repair. The cost shall be calculated according to the valid price list of services and transport costs.

If the Seller finds out (by testing) that the product is not damaged, the Warranty Claim is not accepted. The Seller reserves the right to claim a compensation for costs arising from the false Warranty Claim.

In case the Buyer makes a claim about the Goods that is legally covered by the Warranty provided by the Seller, the Seller shall fix the reported defects by means of repair or by the exchange of the damaged part or product for a new one. Based on the agreement of the Buyer, the Seller has the right to exchange the defected Goods for a fully compatible Goods of the same or better technical characteristics. The Seller is entitled to choose the form of the Warranty Claim Procedures described in this paragraph.

The Seller shall settle the Warranty Claim within 30 days after the delivery of the defective Goods, unless a longer period has been agreed upon. The day when the repaired or exchanged Goods is handed over to the Buyer is considered to be the day of the Warranty Claim settlement. When the Seller is not able to settle the Warranty Claim within the agreed period due to the specific nature of the Goods defect, he and the Buyer shall make an agreement about an alternative solution. In case such agreement is not made, the Seller is obliged to provide the Buyer with a financial compensation in the form of a refund.

CZ
SEVEN SPORT s.r.o.

Registered Office: Strakonická 1151/2c, Praha 5, 150 00, ČR
Headquarters: Dělnická 957, Vítkov, 749 01
Warranty & Service: Čermenská 486, Vítkov 749 01

CRN: 26847264
VAT ID: CZ26847264

Phone: +420 556 300 970
E-mail: eshop@insportline.cz
reklamace@insportline.cz
servis@insportline.cz

Web: www.inSPORTline.cz

SK
inSPORTline s.r.o.

Headquarters, warranty & service center: Električná 6471, Trenčín 911 01, SK

CRN: 36311723
VAT ID: SK2020177082

Phone: +421(0)326 526 701
E-mail: objednavky@insportline.sk
reklamacie@insportline.sk
servis@insportline.sk

Web: www.inSPORTline.sk